

Operator Manual ***Bookletmaker SR 85***

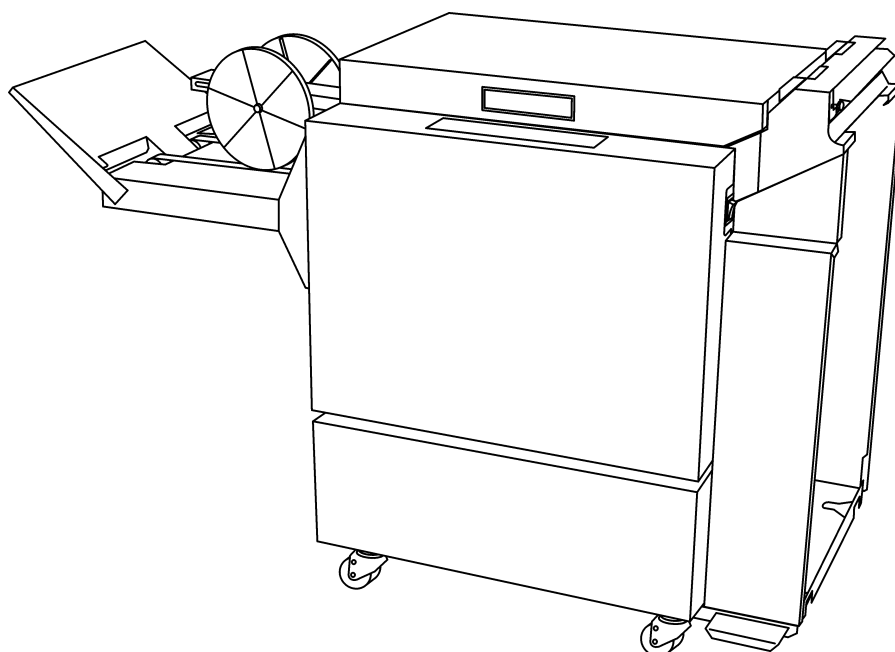

Februari 2001

Part No. 75656

Table of contents

1. Introduction	Page
1.1 Operational safety	1-1
2. Getting to know the SR 85	
2.1 Main components	2-1
2.2 Control panel	2-3
3. Operating and finishing modes	
3.1 The operating modes	3-1
3.2 The finishing modes	3-1
3.3 Jam indications	3-2
4. Operator instructions	
4.1 Docking / undocking the Bookletmaker	4-1
4.2 Setting / Changing paper size	4-2
4.3 Positioning the output wheels	4-3
4.4 Begin the production	4-4
5. Maintenance	
5.1 Replacing the staple cartridge	5-1
5.2 Replacing the stapler head / clearing stapler jam	5-1
5.3 Cleaning of fold rollers	5-3
5.4 GFI function test and resetting	5-3
6. Problem solving	
6.1 Problem solving	6-1
7. Specifications	
7.1 Specifications	7-1

1. Introduction

1.1 Operational safety

Attention to the following notes ensures the continued safe operation of your equipment.

Always connect the equipment to a properly grounded power source receptacle. In doubt, have the receptacle checked by a qualified electrician.

WARNING: Improper connection of the equipment grounding conductor can result in electrical shock.

Always follow all warnings marked on, or supplied with, the equipment.

Always locate the equipment on a solid support surface with adequate strength for the weight of the machine.

Always exercise care in moving or relocating the equipment.

Always keep magnets and all devices with strong magnetic field away from the machine.

Never use a ground adapter plug to connect the equipment to a power source receptacle that lacks a ground connection terminal.

Never attempt any maintenance function that is not specifically described in this documentation.

Never remove the covers or guards that are fastened with screws.

Never install the unit near a radiator or any other heat source.

Never override or “cheat” electrical or mechanical interlock devices.

Never operate the equipment if you notice unusual noises or odours. Disconnect the power cord from the power source receptacle and call your customer service engineer to correct the problem.

2. Getting to know the SR 85

Take a few minutes to become familiar with the main components of the SR 85.

2.1 Main components

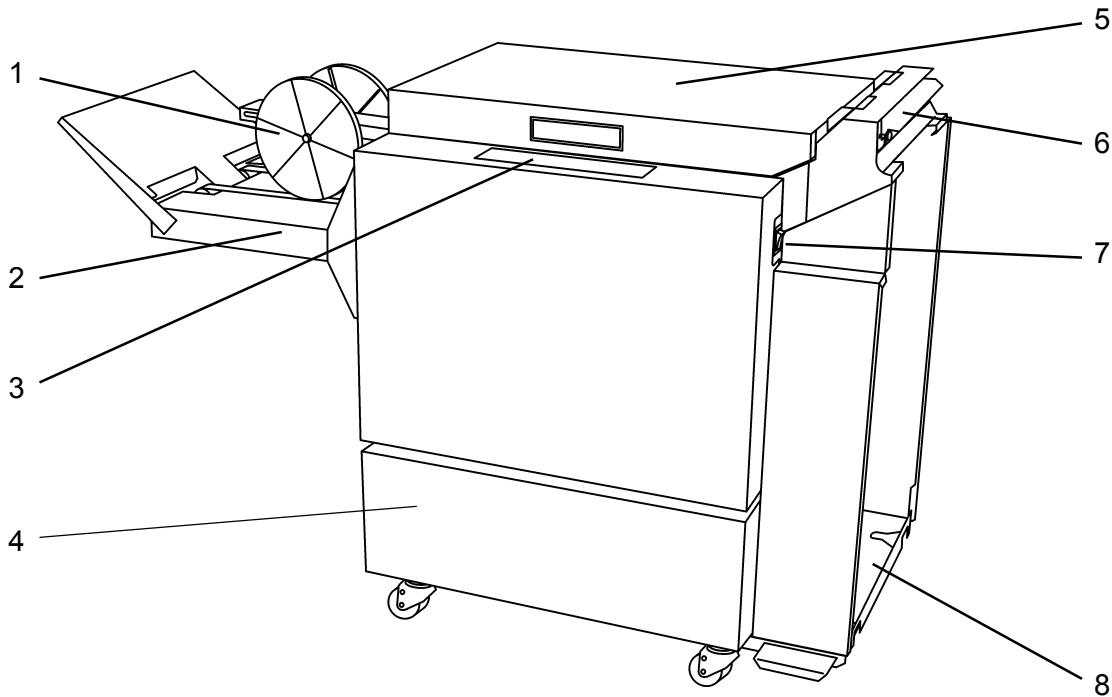

- 1. Output wheels
- 2. Belt stacker
- 3. Control panel
- 4. Base

- 5. Top cover
- 6. Infeed assembly
- 7. Power switch
- 8. Docking assembly

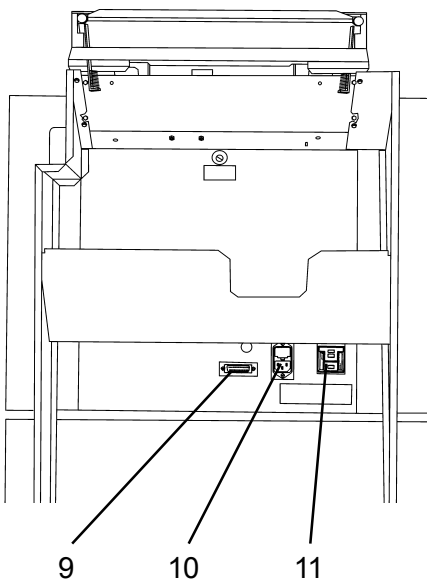

- 9. Connection cable outlet
- 10. Power cord receptacle incl. fuses
- 11. Ground fault interruptor (GFI)

2.1 Main components, continues

When operating the SR 85 you will required to move internal parts of the machine when making adjustments for the stapling and folding of your booklets, or when performing maintenance activities. Take a few minutes to become familiar with these internal components.

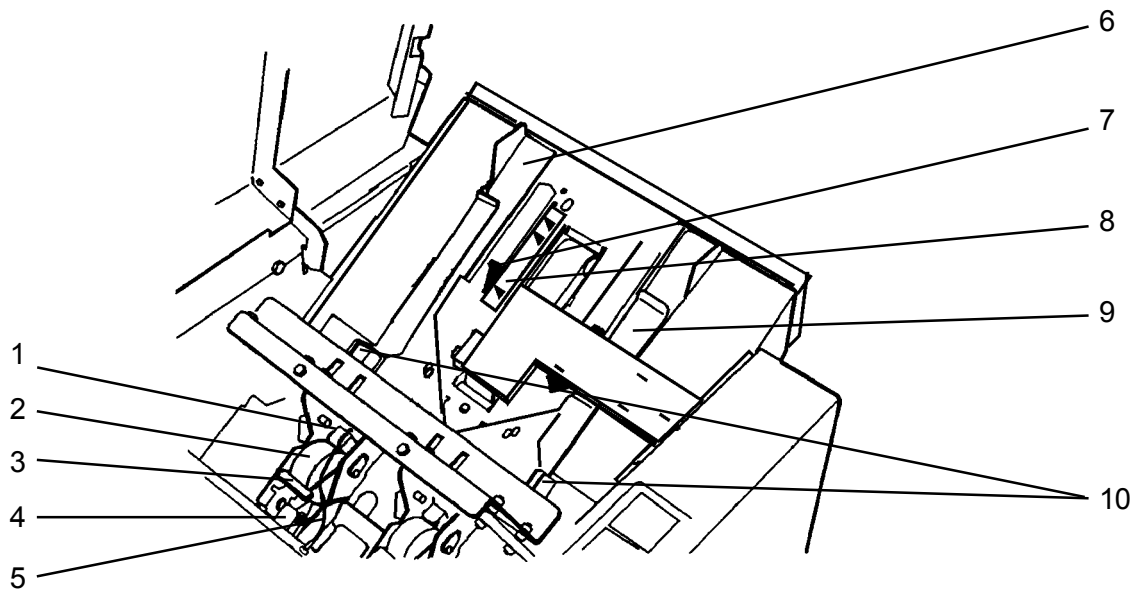

- | | | | |
|----|-------------------------|-----|----------------------------|
| 1. | Stapler head | 6. | Side guide, rear |
| 2. | Staple cartridge | 7. | Back jogger |
| 3. | Cartridge locking lever | 8. | Scale, length adjustment |
| 4. | Stapler release latch | 9. | Side guide front |
| 5. | Staple detection lead | 10. | Release handle, Side guide |

2.2 Control panel

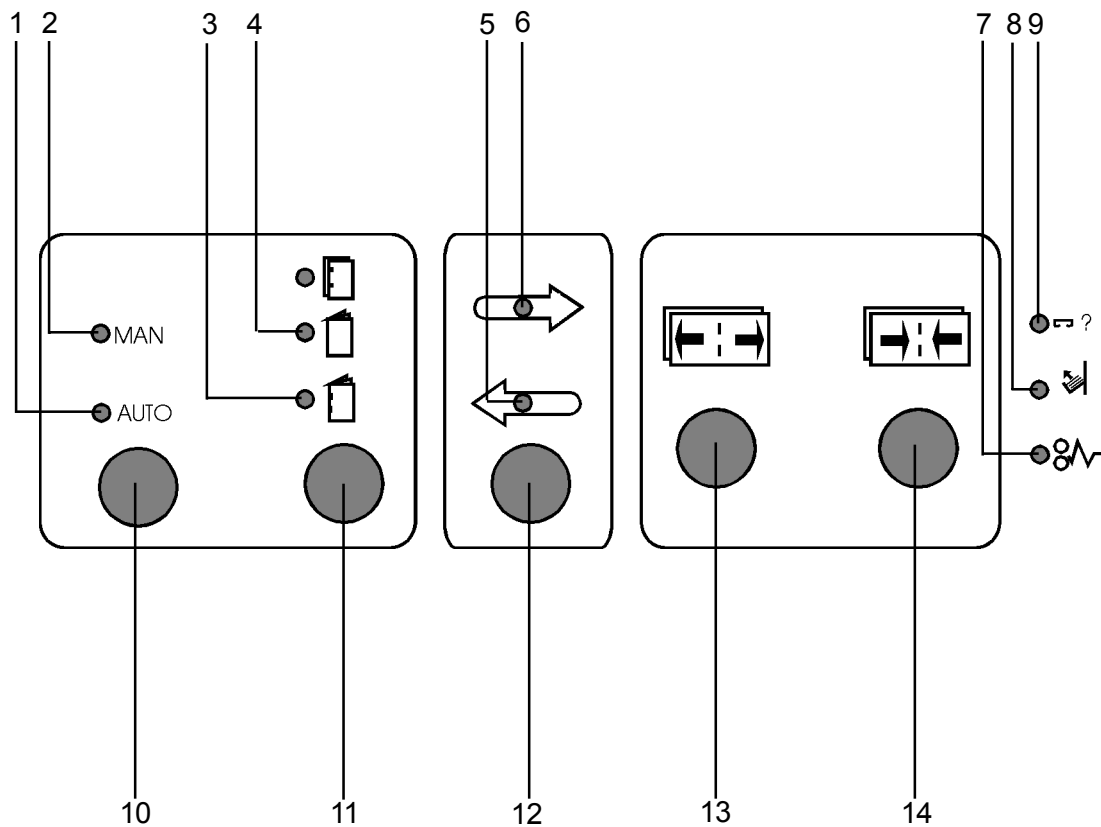

- | | | | |
|----|--------------------------------|-----|------------------------------------|
| 1. | Auto mode indicator | 8. | Stacker full indicator |
| 2. | Manual mode indicator | 9. | Staple(s) missing indicator |
| 3. | Staple and fold mode indicator | 10. | Manual / Auto mode button |
| 4. | Fold mode indicator | 11. | Program select button |
| 5. | Run mode indicator | 12. | Run / Adjustment button |
| 6. | Adjustment mode indicator | 13. | Length adjustment button, increase |
| 7. | Paper jam indicator | 14. | Length adjustment button, decrease |

3. Operating and finishing modes

The SR 85 can be operated in several combinations of modes. These modes are two operating modes and two finishing modes. In this section we will explain the different modes and how they are selected.

3.1 The operating modes

The two operating modes are:

● MAN

● AUTO



1. Manual mode

The manual mode is set on a unit, that should be used as a "stand alone" unit, and is fed manually.

The Manual mode is set by pressing the Manual / Auto mode button on the Control panel and is shown by the Manual mode indicator-LED.

2. Automatic mode

The Automatic mode is set on a unit, that is to operate together with a collator as an on-line system.

The Automatic mode is set by pressing the Manual / Auto mode button on the Control panel and is shown by the Automatic mode indicator-LED.

3.2 The finishing modes

The two finishing modes are:

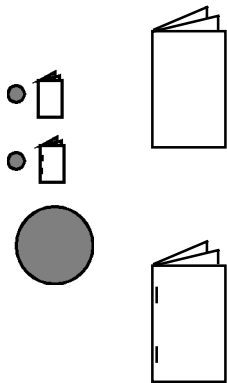

1. Fold only

When selecting this mode by pressing the Program select button, the stapler movement is switched off and the folded set will exit at the upper output area on to the belt stacker.

2. Saddle stapling and fold

When selecting this mode by pressing the Program select-button, the stapled and folded sets will exit at the upper output area on to the belt stacker.

3.3 Jam indications



1. **Staple(s) missing indicator**

The staple(s) missing indicator is illuminated when a set is missing one or two staples. The SR 85 will automatically shut down the on-line system when this indicator LED is lit.

If indication is lit after loading a new staple cartridge, open and close the Top cover. The SR 85 will now cycle and advance for a maximum of 5 stapling movements to regain stapled sets.

Reloading the stapler heads is described in section 5.

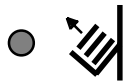

2. **Stacker full indicator**

The Stacker full indicator is illuminated when the belt stacker is full.

Remove the completed sets.



3. **Paper jam indicator**

The Paper jam indicator is illuminated when an operation in the SR 85 is not done within the preset time. Open the top cover and remove the jammed sets reachable, close the top cover and the SR 85 will automatically purge remaining jammed sets.

4. Operator instructions

4.1 Docking / undocking the Bookletmaker

Docking the Bookletmaker

1. Turn the Copier off.
2. Make sure the Bookletmaker is turned off.
3. Lift up the exit arm catcher and set the exit paper arm (1) in the upper position.
4. Remove the shift tray (2) from the finisher and put it on the shelf on the Bookletmaker.
5. Turn the Copier on, the shift tray will now go down to the lower position (3).
6. Turn the Copier off.
7. Move the Bookletmaker up to the Copier and dock it.
8. Turn the Bookletmaker on.
9. Turn the Copier on.

The Copier is now in Bookletmaker mode.

Undocking the Bookletmaker

1. Turn the Bookletmaker off.
2. Turn the Copier off.
3. Push in the latch (4) on the docking assembly.
4. Move the Bookletmaker away from the Copier. Note: Be careful with the communication cable.
5. Lift up the exit arm catcher and move the exit paper arm to the lower position (5).
6. Take the shift tray from the shelf on the Bookletmaker, and install it on the finisher (2).
7. Turn the Copier on, the shift tray will now go up to the upper position.

The Copier is now in standard Copier mode.

Note: It's very important to turn on and off the machines in the correct sequence.

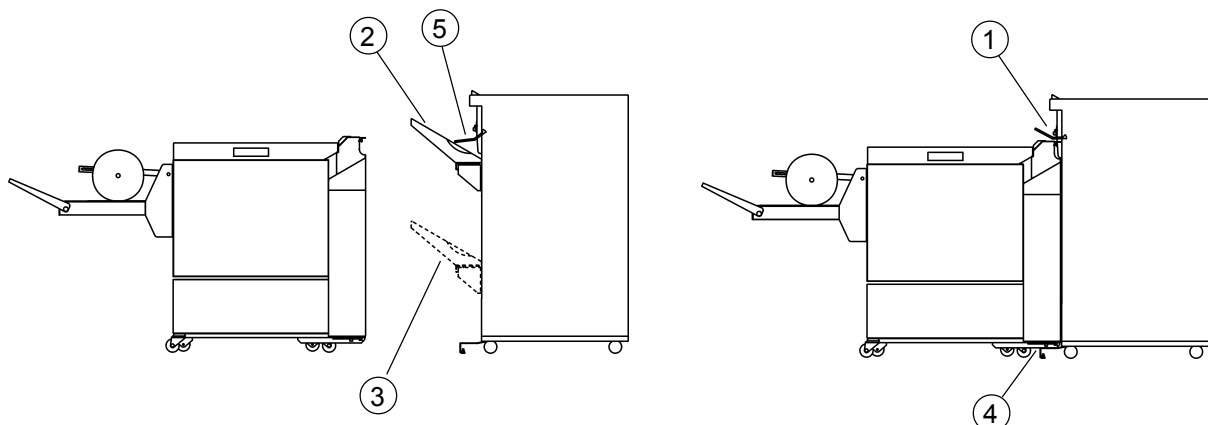

4.2 Setting / Changing paper size

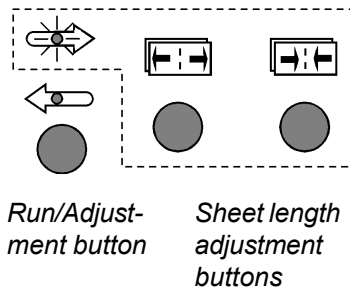
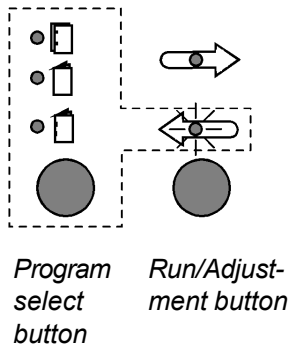

1. Select one of the programs Edge stapling, only Folding or Stapling/Folding at the Control panel.
2. Open the top cover and press the Run/Adjustment button to access the Adjustment buttons on the Control panel.
3. Adjust the front and rear Side guide to the paper format that will be used. Adjust the side guides by squeezing on the two release handles.
4. Adjust the sheet length slightly larger than the paper size being used. Close the top cover.
5. Feed one test set into the SR 85. Open the top cover and adjust the sheet length so that the trail edge of the set just touches the backjogger. Close the top cover and push the Run / Adjustment button to exit the Adjustment mode.

4.3 Positioning the output wheels

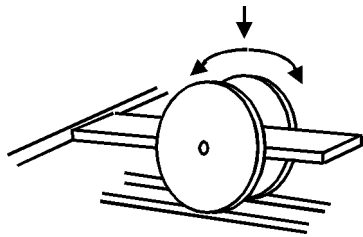
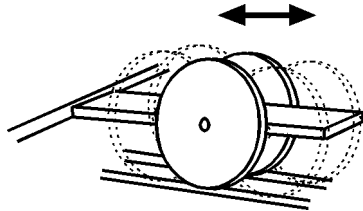

The output wheels can be positioned in three different positions.

These are:

1. The A4 / 8.5 x 11" position.
Use this position when making booklets from A4 (8.5 x 11") size paper.
2. The 8.5 x 14" position. (N/A on A4 / A3 Machines)
Use this position when making booklets from 8.5 x 14" size paper.
3. The A3 / 11 x 17" position.
Use this position when making booklets from A3 (11 x 17") size paper.
4. The outermost position.
Use this position when storing the equipment or for easy access to the delivery tray when edge stapling. This allows you to fold the Belt stacker to an upright position.

When unfolding the Belt stacker, the End plate should be in 30 degree angle for maximum load capacity.

To change the position of the Output wheels, do the following:

1. Place the wheels on the conveyor belts .
2. Shift position by turning the Output wheels while placed on the belts.

4.4 Begin the production

1. Make sure the Bookletmaker is set for A4 or A3. If not, adjust according to 4.2 setting / changing paper size.
2. Select paper tray.
3. Select staple.
4. Select Dup / Combine / Series.
5. Select Book.
6. Select Magazine.
7. Send one A4 / A3 proof set from the Printer by pressing the "proof button on the printer"

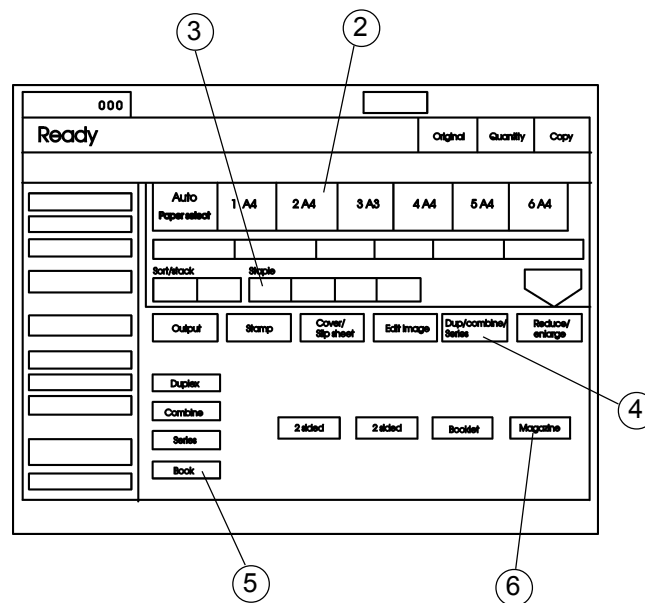

5. Maintenance

5.1 Replacing the staple cartridge

You may remove and replace the staple cartridge while the stapler head is in place within the SR 85. The staple cartridges contain approximately 5000 staples per cartridge and can be replaced as often as necessary.

1. If the staples missing indicator is illuminated, open the Top cover and remove eventual jammed sets.

NOTE: One set must be left in stapling position (see item 8 below).

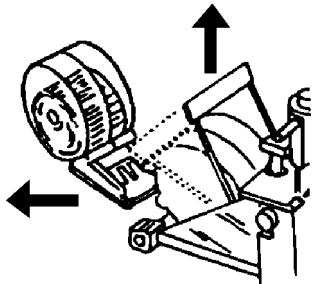

2. Raise the red handle on the staple cartridge Locking lever.

3. Remove the staple cartridge from the stapler head by sliding it to the left.

4. If the cartridge is empty, discard it and replace it with a new one. Before replacing the cartridge, pull 25 mm (1 inch) of staples out of the cartridge and tear the staples downward against the staple tear line. The staple tear line is indicated by an arrow on the side of the cartridge.

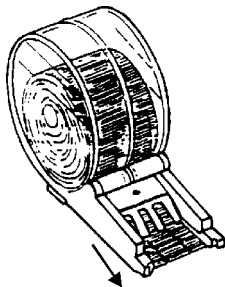

5. If there has been a misfeed, and if it is necessary to remove the cartridge in order to clear the misfeed, pull 25 mm (1") of staples out of the cartridge and tear the staples downward against the staple tear line before re-installing the cartridge.

6. Insert the cartridge into the stapler head with the end of the staples facing toward the head of the stapler mechanism. Push it firmly ahead.

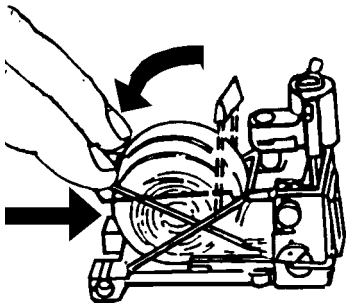

7. Hold the staple cartridge firmly in place and push down the cartridge locking lever. Close the Top cover.

8. The SR 85 will automatically cycle and advance staples until both staple heads are driving staples for a maximum of 5 stapling movements.

5.2 Replacing the stapler head / clearing stapler jam

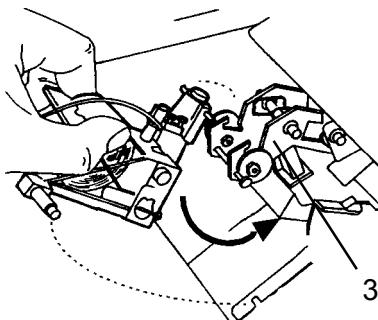
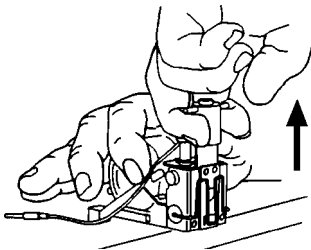
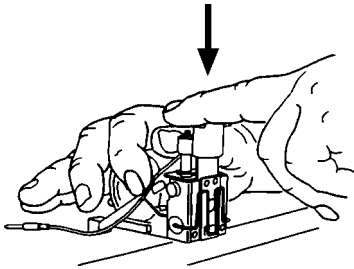
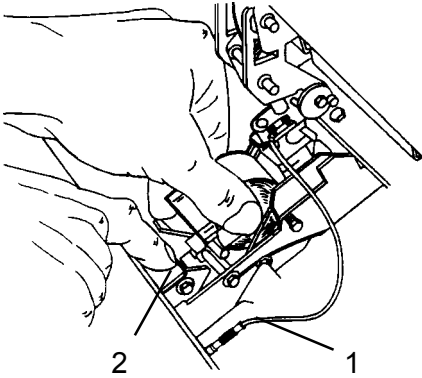

1. Switch the power switch to OFF (0) position. Open the Top cover on the SR 85. Disconnect the staple indication lead (1) from the socket.
2. Hold the stapler head in place, press the release lever (2) to release the rear end of the stapler head and lift up this end.
3. Lift out the head, allowing it to rotate around the front end. The stapler assembly is spring loaded and will follow the rotation of the stapler.
4. Position the stapler head on the edge of a firm surface (for example, the top of a table or the SR 85).
5. While securely holding the head, actuate the stapler up and down through full travel. Repeat this a few times to ensure that the staples are ejected at each down movement.
6. To reinstall the stapler head, insert the pin at the top of the stapler head into the stapler retraction swing arm (3).
7. While rotating the stapler head, insert the pin located at the rear end of the stapler head into the slots in the frame of the stapler head assembly. Press down the rear end of the stapler head until the release lever snaps into place, locking the stapler head in position.
8. Press down the front end of the stapler head until it snaps in position under the frame assembly.
9. Reconnect the staple indication lead (1).

5.3 Cleaning of fold rollers

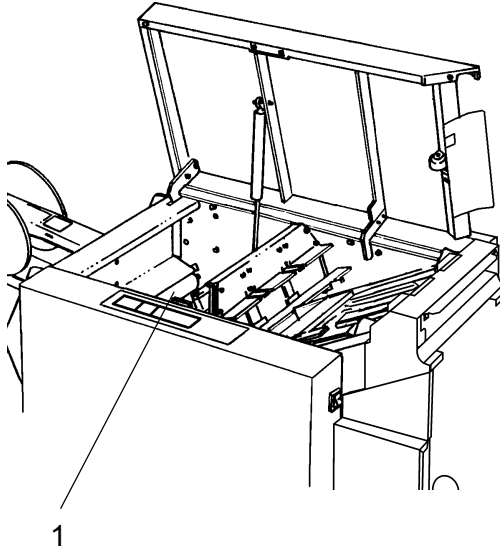

The Fold rollers needs to be cleaned regularly when in use. How often this should be done is depending on what kind of paper stock that is operated through the unit.

1. Open the Top cover. Clean the accessible areas of the Fold rollers (1) with rubber reactivator fluid. Clean from both the inside of the unit and through the output opening.
2. Close the Top cover and run one set of a two sheets through the unit.
3. Repeat step 1 and 2 until rollers are cleaned (approx.. 2-3 times).

5.4 GFI function test and resetting

WARNING: DO NOT use the SR 85 if the following test fails. No additional testing should be performed. Call for service.

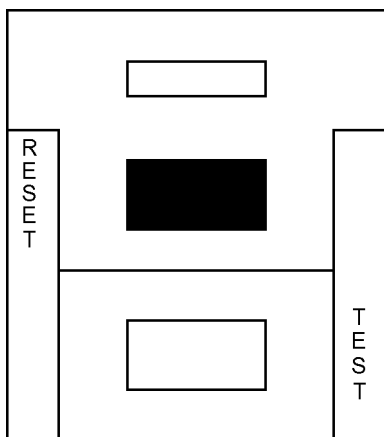

When testing the Ground Fault Interrupter (GFI), the SR 85 Power cord must be connected to the wall receptacle and the Main Power switch in the ON (1) position.

1. Press the red "TEST"- button.
2. Press the black "RESET"-button. A red flag should appear in the window of the GFI.
3. Press the red "TEST"- button. The red flag should disappear.
4. Press the black "RESET"-button again. The SR 85 should now be ready to use.

6. Problem solving

6.1 Problem solving

PROBLEM	POSSIBLE CAUSES	ACTION
Front panel does not light up.	Power cord not connected. Ground Fault Interruptor released. Fuse in the power cord receptacle defective.	Connect power cord. Check the GFI according to 5.4. Replace fuse.
Poor jogging of sets.	Front and rear Paper guides not adjusted properly to the set. Back jogger not adjusted properly to the set.	Check/correct according to 4.2. Check/correct according to 4.2.
Out of staple indicator illuminated on front panel.	Staple cartridge empty. Staple jammed in stapler head.	Replace according to 5.1. Remove head according to 5.2 and clear jam.
Deformed staples.	Foreign objects in stapler head. Too many sheets / too heavy stock.	Remove head according to 5.2 and clean head. Check and correct according to specifications section 7.1
Set is incorrectly folded.	Sheet length incorrectly adjusted.	Check/correct according to 4.2.

7. Specifications

7.1 Specifications

	Booklet Maker SR 85
Stapling / Folding capacity	20 sheets of 80 gsm
Length range	279 x 432 mm / 11" - 17"
Width range	210 x 300 mm / 8,3" - 11,8"
Paper weight minimum	64 gsm / 17 lb.
Paper weight maximum	163 gsm / 43 lb.
Stapler heads	2
Speed booklet making	2 A4 / 8,5" x 11" sheets from the printer 800 books / hour 2 A3 / 11" x 17" sheets from the printer 500 books / hour
Missed staple detection	Yes
Empty cartridge detection	Yes
Paper jam detection	Yes
Stacker full detection	Yes
Total counter	Yes
Length (stacker folded up)	873 mm
Length (stacker folded down)	1378 mm
Height	815 mm
Width	595 mm
Weight	91 kg
Voltage	230/240V 50Hz 115V 60Hz